

**S.U.G.W.R. PLAN**  
Scale-1:50  
CAPACITY  
600 GLS

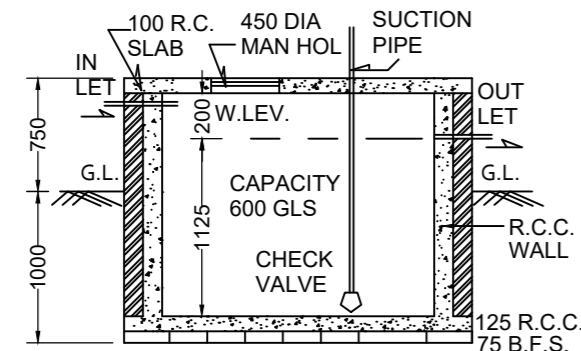

**S.U.G.W.R. DETAILS**  
Scale-1:50

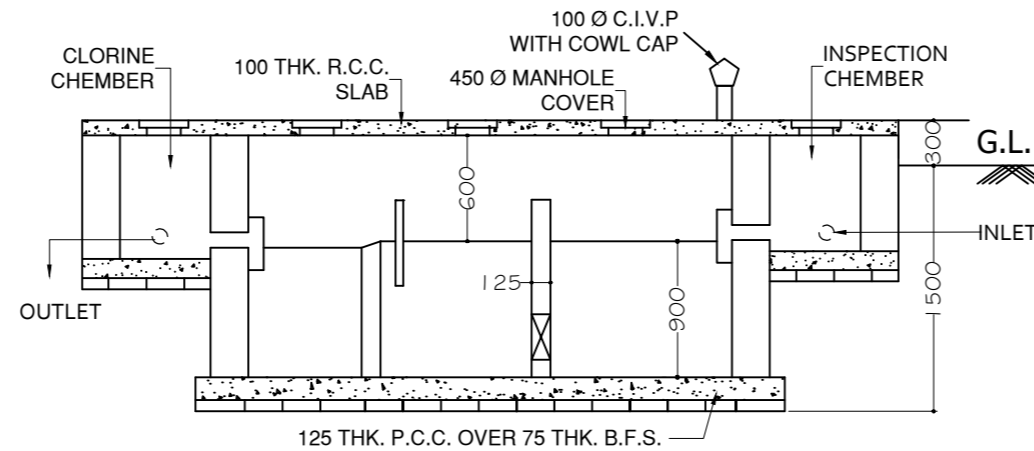

**SECTION ON Y - Y'**  
Scale-1:50

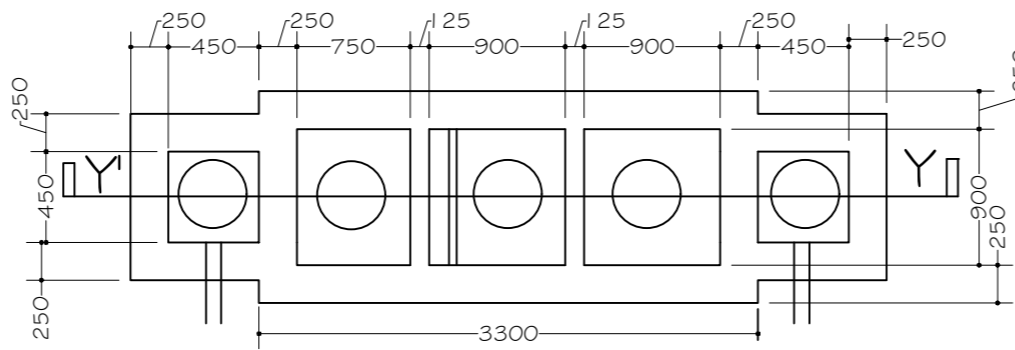

**SEPTIC TANK PLAN**  
SCALE - 1 : 50  
CAPACITY - 30 USERS

**P.A.S. ROAD CONNECTOR**

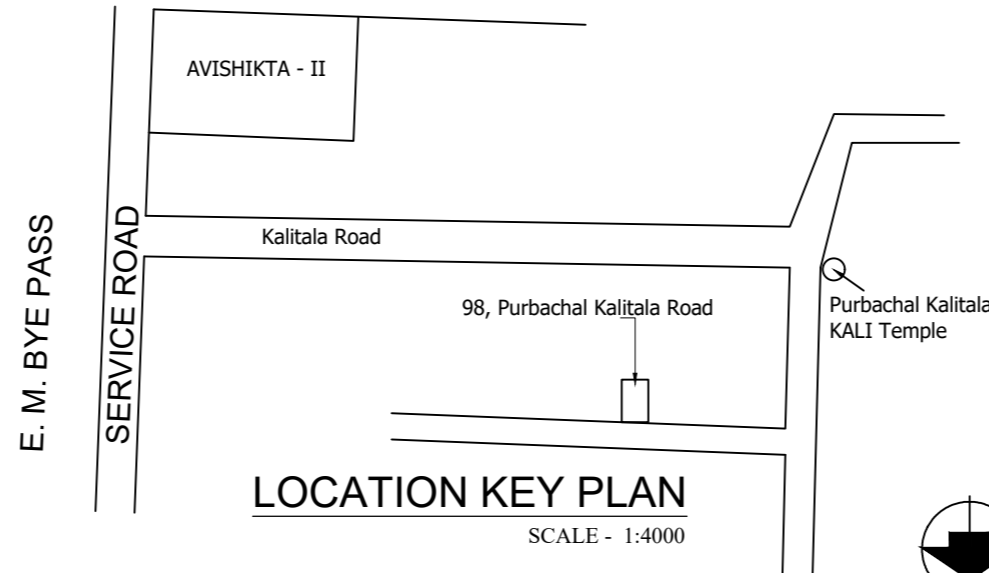

**LOCATION KEY PLAN**  
SCALE - 1:4000

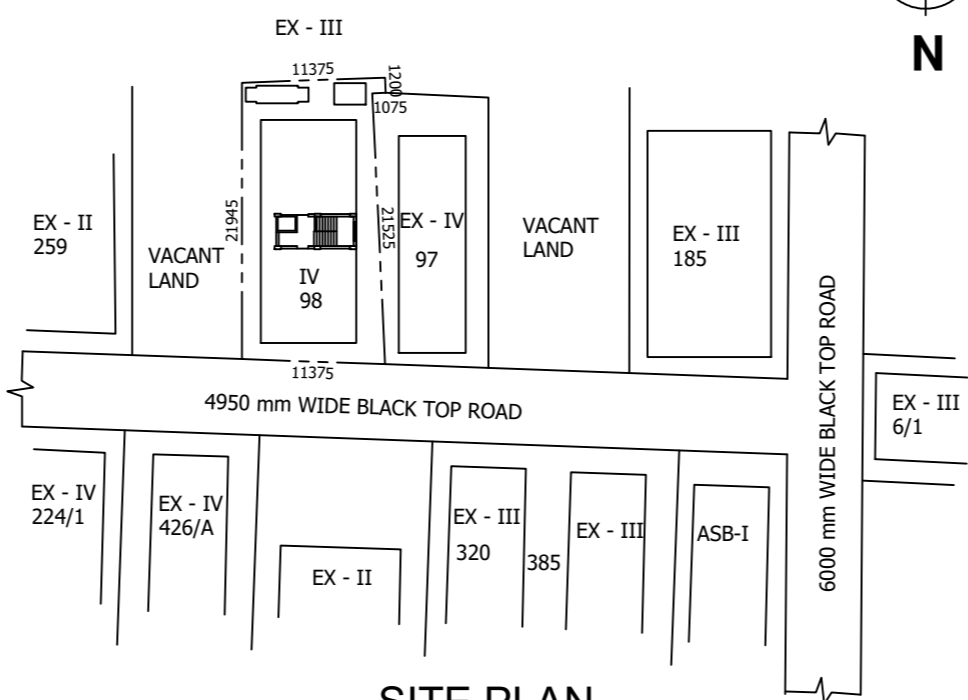

**SITE PLAN**  
SCALE - 1 : 600

**SPECIFICATIONS & NOTES :-**

1. ALL DIMENSIONS ARE IN 'MM' IF NOT OTHERWISE STATED.
2. GRADE OF R. C. CONCRETE - M20 [1 : 1.5 : 3]
3. GRADE OF P. C. CONCRETE - M100 [1 : 3 : 6]
4. GRADE OF TOR STEEL - Fe 415.
5. THE DEPTH OF W.R. FOUNDATION WILL NOT BE EXCEED TO THE DEPTH OF BUILDING FOUNDATION
6. ALL SPECIFICATION AND MATERIALS USED IN I.S. CODE & N.B. C. OF INDIA
7. ALL STEEL CUTTING LENGTH - L/3. & BEND - 40 d.
8. ALL EXTERIOR WALL IS 200MM THK SAND MORTAR.
9. ALL INTERNAL PARTITION WALL ARE 75 MM THK. WITH 1 : 4 CEMENT MORTER

**MAIN CHARACTERISTICS OF THE PROPOSAL**

**PART - A**

1. ASSESSEE NO:- 31-106-15-0098-8
2. DET. OF REGD. TITLE DEED- Book No. -I, Vol. No- 69, Page - 49 TO 68, Being No. - 2600, Date.- 26/06/1997, Regd. - D.S.R. - III, 24 - Parganas South
3. NAME OF THE OWNER/APPLICANT- SRI RUPESH DUTTA PROPRIETOR OF M/S RUPESH DUTTA & C.A. OF SMT. ANJANA MAJUMDER
4. Details of Power of Attorney, if any - Nil  
Book No. -I, Vol. No- 1603-2025, Page - 90842 TO 90853, Being No. - 160303635, Date.- 28/02/2025, Regd. - D.S.R. - III, 24 - Parganas South
5. Details of Boundary declaration - 243.049 Sqm  
Book No. -I, Vol. No- 1603-2025, Page - 90882 TO 90893, Being No. - 160303633, Date.- 28/02/2025, Regd. - D.S.R. - III, 24 - Parganas South
6. Mutation (K.M.C.) - O/106/24-MAY-13/13872 Dt. 24/05/2013.
7. Certificate of Conversion - Memo No. 17/3179/BLLRO/KOL, Dated - 26/09/2024.

**PART - B**

1. AREA OF LAND- As Per Title Deed - 250.836 Sqm. (3k-12ch-0sft)
2. NET AREA OF LAND- 243.049 Sqm.
3. PERMISSIBLE GROUND COVERAGE - 58.565 % = 142.342 Sqm.
4. PROPOSED GROUND COVERAGE - 55.243 % = 134.267 Sqm.
5. PROPOSED AREA -

	Fl. covered Area (gross)	Lift well Area	Fl. covered Area (Net)	Total Exempted area		Net Fl. Area
				Stair+St.Lobby	Lift.Lobby	
Gr. Fl.	100.269	-	100.269	10.463	1.678	88.128
1st. Fl.	134.267	1.540	132.727	10.463	1.678	120.596
2nd. Fl.	134.267	1.540	132.727	10.463	1.678	120.596
3rd. Fl.	134.267	1.540	132.727	10.463	1.678	120.596
Total	503.070	4.620	498.450	41.852	6.712	449.886

**6. PARKING CALCULATION -**

TENEMENT MARKED	NET TENEMENT AREA (SQM.)	PROPORTIONATE COMM. AREA (SQM.)	GROSS TENEMENT AREA (SQM.)	NO. OF TENEMENT	REQD. PARKING	TOTAL REQUIRED PARKING	
						01	01
A	59.897	10.794	70.691	06	01	01	

- Nos. of Parking provided - 01
- Permissible area for parking - 25.0 Sqm
- Actual area for parking provided - 74.306 Sqm.
- PERMISSIBLE F.A.R. - 1.75
- PROPOSED F.A.R. - 1.748
- Additional area for fees - 31.44 Sqm.
- 9A. C.B. Area - 8.323 Sqm.
- Staircase covered area - 12.603 Sqm.
- Lift M/C. Rm. area - 8.039 Sqm.
- O.H.W.T area, - 8.051 Sqm.
- Tree Cover area - 0.903 Sqm
- LMR Stair area - 2.475 Sqm

REFERENCE POINTS MARKED IN THE SITE PLAN OF THE PROPOSAL	CO-ORDINATE IN WGS 84		SITE ELEVATION (AMSL)
	LATITUDE	LONGITUDE	
1	22.5071	88.3980	6.57 MT.
2	22.5070	88.3981	6.57 MT.

Permissible height in reference to CCZM issued by AAI: 33 Mt.

**SCHEDULE OF DOOR & WINDOW**

D1 = 1000 X 2100, D2 = 900 X 2100, D3 = 750 X 2100, W/1 = 1500 X 1200, W/2 = 900 X 1200, W/3 = 600 X 750

**CERTIFICATE OF GEO-TECH. ENGINEER**

UNDERSIGNED HAS INSPECTED THE SITE AND CARRIED OUT SOIL INVESTIGATION THEREON. IT IS CERTIFIED THAT THE EXISTING SOIL OF THE SITE IS ABLE TO CARRY THE LOAD COMING FROM THE PROPOSED CONSTRUCTION AND THE FOUNDATION SYSTEM PROPOSED HERE IN IS SAFE AND STABLE IN ALL RESPECT FROM GEO-TECHNICAL POINT OF VIEW.

NAME OF G.T.E. - ASIM SARKAR (NO.-2, CLASS - I)

**E.S.E. CERTIFICATE**

THE STRUCTURAL DESIGN AND DRAWING OF BOTH FOUNDATION AND SUPER STRUCTURE OF THE BUILDING HAS BEEN MADE BY ME CONSIDERING ALL POSSIBLE LOADS INCLUDING THE WIND LOAD & SEISMIC LOAD AS PER THE N.B.C. OF INDIA AND CERTIFIED THAT IT IS SAFE AND STABLE IN ALL RESPECT.  
SOIL TESTING HAS BEEN DONE BY SRI ASIM SARKAR OF M/S, ASSOCIATED FOUNDATION ENGINEERS. THE RECOMMENDATIONS OF SOIL TEST REPORT HAS BEEN CONSIDERED DURING STRUCTURAL CALCULATIONS.

NAME OF E.S.E. - ASIM SARKAR (NO.-136, CLASS - I)

**L.B.S. CERTIFICATE**

THE PLOT IS A VACANT LAND, OCCUPIED BY OWNER. THERE IS NO TENANT.  
THE PLOT IS BOUNDED BY BOUNDARY WALL & BOUNDARY MEASUREMENT AGREED WITH THE REGD. DEED PLAN.  
THE WIDTH OF THE ROAD IS 5.950 M ON THE NORTH SIDE.  
CERTIFIED WITH FULL RESPONSIBILITY THAT THE BUILDING PLAN HAS BEEN DRAWN UP AS PER PROVISION OF K.M.C. BUILDING RULES 2009, AS AMENDED FROM TIME TO TIME AND THAT THE SITE CONDITION INCLUDING THE WIDTH OF THE ABUTTING ROAD CONFORM WITH THE PLAN AND THAT IT IS A BUILDABLE SITE NOT A TANK OR FILLED UP TANK.  
SIGNATURE OF OWNERS IS IDENTIFIED BY ME. THE PLOT IS SITUATED WITHIN 500 MT. FROM THE CL OF E.M. BYE PASS.

NAME OF PALLAB DAS (C.A/89/12363)

**OWNERS DECLARATION**

I DO HEREBY DECLARE WITH FULL RESPONSIBILITY THAT WE SHALL ENGAGE ARCHITECT & E.S.E. DURING CONSTRUCTION, I SHALL FOLLOW THE INSTRUCTION OF ARCHITECT & E.S.E. DURING CONSTRUCTION OF THE BUILDING (AS PER B.S. PLAN) K.M.C. AUTHORITY WILL NOT BE RESPONSIBLE FOR STRUCTURAL STABILITY OF THE BUILDING & ADJOINING STRUCTURES.  
IF ANY SUBMITTED DOCUMENTS ARE FOUND TO BE FAKE, THE K.M.C. AUTHORITY WILL REVOKE THE SANCTION PLAN. THE CONSTRUCTION OF WATER RESERVOIR AND SEPTIC TANK WILL BE UNDERTAKEN UNDER THE GUIDANCE OF E.S.E./ARCHITECT BEFORE STARTING OF BUILDING FOUNDATION WORK. THE PLOT IS IDENTIFIED BY ME. IF ANY DISCREPANCY ARISE REGARDING THEN, THEN ARCHITECT & K.M.C. AUTHORITY WILL NOT BE RESPONSIBLE FOR THAT AND K.M.C. WILL EVERY RIGHT TO REVOKE THE PLAN.

NAME OF SRI RUPESH DUTTA PROPRIETOR OF M/S RUPESH DUTTA & C.A. OF SMT. ANJANA MAJUMDER

**BUILDING PERMIT NO. 2025120086**

**DATE - 02-JUN-25**

**VALID UP TO - 01-JUN-30**

**SUBRATA NAG**

Digitally signed by SUBRATA NAG  
Date: 2025.06.02 13:35:51 +05'30'

N.A.

DIGITAL SIGNATURE OF A.E.

DIGITAL SIGNATURE OF E.E.

**PROPOSED G + THREE STORIED (HT. 12.475 M) RESIDENTIAL BUILDING PLAN AT PREMISES NO. 98, PURBACHAL KALITALA ROAD, WARD NO.- 106, BOROUGH NO.- XII, KOLKATA - 700 078, R.S. DAG NO. - 4139/4315, KHATIAN NO. - 269, MOUZA - KASBA, TOUZI NO. - 145, J.L. 13, P.S. - GARFA, U/S 393A OF KMC BLDG. ACT. 1980 & AS PER BLDG. RULE 2009.**

**ARCHITECTURAL PLAN**

SCALE -	1 : 100 IF NOT OTHERWISE STATED		
DRG.NO.	A/04/RSB/25		
SHEET NO.	1/2		
	REV. -	0	
Date -	04/04/2025.		

**R. S. BUILDING**  
883, RAJDANGA MAIN ROAD  
KOLKATA - 700 107

